

NON-METALLIC SPUR GEARS

20° PRESSURE ANGLE PIN HUB

72 PITCH
3/16 FACE
3/16 BORE

Guaranteed to Quality 10 at time of gear cutting.

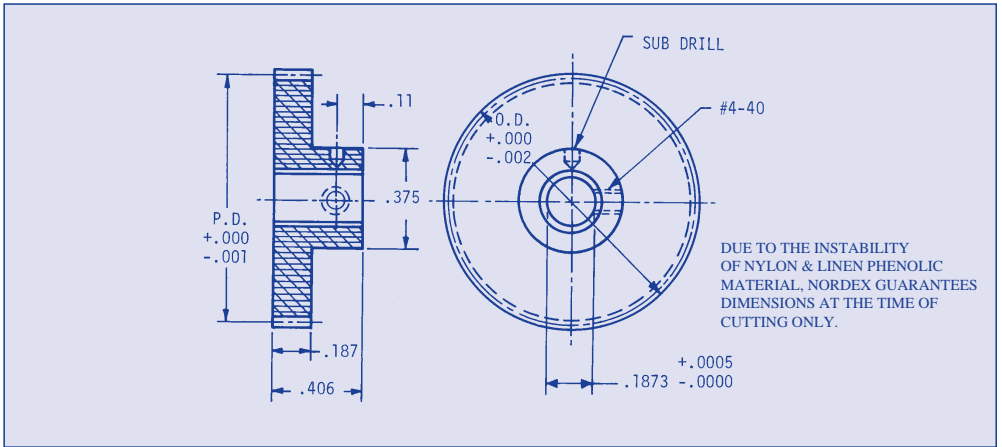

Material: Nylon with 300 Series stainless steel bore sleeve.
Linen Phenolic

ORDER BY CATALOG NUMBER

NYLON*	LINEN PHENOLIC	GEAR DATA		
Cat. No.	Cat. No.	No. of Teeth	Pitch Diameter	Outside Diameter
LLN-G2-30	LLL-G2-30	30	.4167	.444
LLN-G2-31	LLL-G2-31	31	.4306	.458
LLN-G2-32	LLL-G2-32	32	.4444	.472
LLN-G2-36	LLL-G2-36	36	.5000	.528
LLN-G2-40	LLL-G2-40	40	.5556	.583
LLN-G2-48	LLL-G2-48	48	.6667	.694
LLN-G2-50	LLL-G2-50	50	.6944	.722
LLN-G2-60	LLL-G2-60	60	.8333	.861
LLN-G2-64	LLL-G2-64	64	.8889	.917
LLN-G2-70	LLL-G2-70	70	.9722	1.000
LLN-G2-72	LLL-G2-72	72	1.0000	1.028
LLN-G2-80	LLL-G2-80	80	1.1111	1.139
LLN-G2-90	LLL-G2-90	90	1.2500	1.278
LLN-G2-96	LLL-G2-96	96	1.3333	1.361
LLN-G2-100	LLL-G2-100	100	1.3889	1.417
LLN-G2-120	LLL-G2-120	120	1.6667	1.694

*Stainless steel bore sleeves are supplied in all nylon gears to add rigidity and support the hub for set screw and pinning. Pinning through both hub and sleeve, and the full length contact of the sleeve with hub and face, prevents loosening.