

FLAT SPUR GEARS-HUBLESS

**24 PITCH
1/8 FACE
3/8 BORE**

Designed for use with:

- One way clutches (section "E")
- Cluster gears (section "L")
- Slip clutches (section "E")
- Pin hubs (section "B")
- Screw type hubs (section "B")
- Clamp type hubs (section "B")

Depending on application--
Nordex assembly charges on request.

**** NO LIGHTENING HOLES**

Specifications: Unless otherwise stated, 20° pressure angle, quality #10 or better gears will be supplied. When ordering Q12 or Q14 please supply the catalog number and add Q12 or Q14.

Gear Class	Total Composite Tolerance	Tooth to Tooth Composite Tolerance	Pitch Dia.	Outside Dia.
Q10	.001	.0004	-.001	-.002
*Q12	.0005	.0003	-.0007	-.0015
*Q14	.00025	.0002	-.0005	-.001

Gear tapes certifying accuracy available at additional cost.

ORDER BY CATALOG NUMBER

# 303 STAINLESS STEEL	2024-T4 ALUMINUM ANODIZED BEFORE CUTTING	GEAR DATA		
Cat. No.	Cat. No.	No. of Teeth	Pitch Diameter	Outside Diameter
LCS-C1-15	LCA-C1-15	15	.6250	.708
LCS-C1-16	LCA-C1-16	16	.6667	.750
LCS-C1-17	LCA-C1-17	17	.7083	.792
LCS-C1-18	LCA-C1-18	18	.7500	.833
LCS-C1-19	LCA-C1-19	19	.7917	.875
LCS-C1-20	LCA-C1-20	20	.8333	.917
LCS-C1-21	LCA-C1-21	21	.8750	.958
LCS-C1-22	LCA-C1-22	22	.9167	1.000
LCS-C1-23	LCA-C1-23	23	.9583	1.042
LCS-C1-24	LCA-C1-24	24	1.0000	1.083
LCS-C1-25	LCA-C1-25	25	1.0417	1.125
LCS-C1-28	LCA-C1-28	28	1.1670	1.250
LCS-C1-30	LCA-C1-30	30	1.2500	1.333
LCS-C1-32	LCA-C1-32	32	1.3330	1.417
LCS-C1-33	LCA-C1-33	33	1.3750	1.458

*To produce gear class 12 or 14, the gear must be mounted to its hub before cutting.

**LIGHTENING HOLES available upon request for gears 2 1/8 diameter and over. For hole specifications please refer to product catalog number series KPS-J1 "Flat Gear Blanks" in section K.

FLAT SPUR GEARS-HUBLESS

CONTINUED

**24 PITCH
1/8 FACE
3/8 BORE**

ORDER BY CATALOG NUMBER

# 303 STAINLESS STEEL		2024-T4 ALUMINUM ANODIZED BEFORE CUTTING		GEAR DATA	
Cat. No.	Cat. No.	No. of Teeth	Pitch Diameter	Outside Diameter	
LCS-C1-36	LCA-C1-36	36	1.5000	1.583	
LCS-C1-40	LCA-C1-40	40	1.6667	1.750	
LCS-C1-42	LCA-C1-42	42	1.7500	1.833	
LCS-C1-45	LCA-C1-45	45	1.8750	1.958	
LCS-C1-46	LCA-C1-46	46	1.9167	2.000	
LCS-C1-48	LCA-C1-48	48	2.0000	2.083	
LCS-C1-50	LCA-C1-50	50	2.0833	2.167	
LCS-C1-52	LCA-C1-52	52	2.1670	2.250	
LCS-C1-55	LCA-C1-55	55	2.2920	2.375	
LCS-C1-56	LCA-C1-56	56	2.3330	2.417	
LCS-C1-57	LCA-C1-57	57	2.3750	2.458	
LCS-C1-60	LCA-C1-60	60	2.5000	2.583	
LCS-C1-64	LCA-C1-64	64	2.2670	2.750	
LCS-C1-66	LCA-C1-66	66	2.7500	2.833	
LCS-C1-69	LCA-C1-69	69	2.8750	2.958	
LCS-C1-72	LCA-C1-72	72	3.0000	3.083	
LCS-C1-78	LCA-C1-78	78	3.2500	3.333	
LCS-C1-84	LCA-C1-84	84	3.5000	3.583	
LCS-C1-90	LCA-C1-90	90	3.7500	3.833	
LCS-C1-96	LCA-C1-96	96	4.0000	4.083	
LCS-C1-99	LCA-C1-99	99	4.1250	4.208	

The number of teeth shown does not reflect our entire stock, unlisted teeth supplied at modest additional cost. 14 1/2° pressure angle, special bores and materials - price on application.

EXAMPLES OF HUBLESS AND CLUSTER GEAR ASSEMBLIES

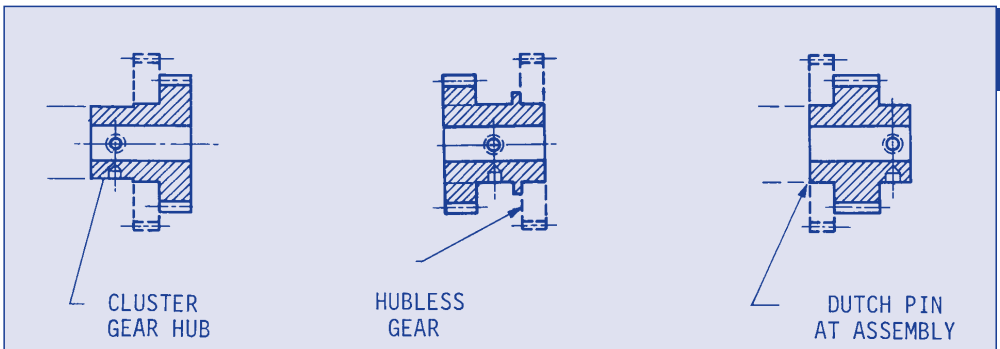

FLAT SPUR GEARS-HUBLESS

20° PRESSURE ANGLE

**24 PITCH
1/4 FACE
3/8 BORE**

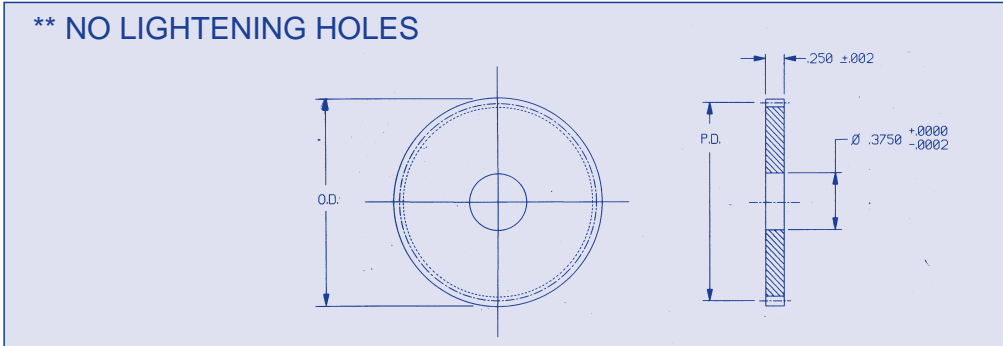

Specifications: Unless otherwise stated, quality #10 or better gears will be supplied. When ordering Q12 or Q14 please supply the catalog number and add Q12 or Q14.

Gear Class	Total Composite Tolerance	Tooth to Tooth Composite Tolerance	Pitch Dia.	Outside Dia.
Q10	.001	.0004	-.001	-.002
Q12	.0005	.0003	-.0007	-.0015
Q14	.00025	.0002	-.0005	-.001

Gear tapes certifying accuracy available at additional cost.

ORDER BY CATALOG NUMBER

# 303 STAINLESS STEEL	2024-T4 ALUMINUM ANODIZED BEFORE CUTTING	GEAR DATA		
Cat. No.	Cat. No.	No. of Teeth	Pitch Diameter	Outside Diameter
LCS-C2-24	LCA-C2-24	24	1.0000	1.083
LCS-C2-26	LCA-C2-26	26	1.0830	1.167
LCS-C2-30	LCA-C2-30	30	1.2500	1.333
LCS-C2-32	LCA-C2-32	32	1.3333	1.417
LCS-C2-36	LCA-C2-36	36	1.5000	1.583
LCS-C2-40	LCA-C2-40	40	1.6667	1.750
LCS-C2-44	LCA-C2-44	44	1.8333	1.917
LCS-C2-48	LCA-C2-48	48	2.0000	2.083
LCS-C2-52	LCA-C2-52	52	2.1667	2.250
LCS-C2-56	LCA-C2-56	56	2.3333	2.417
LCS-C2-60	LCA-C2-60	60	2.5000	2.583
LCS-C2-64	LCA-C2-64	64	2.6667	2.750
LCS-C2-72	LCA-C2-72	72	3.0000	3.083
LCS-C2-84	LCA-C2-84	84	3.5000	3.583
LCS-C2-96	LCA-C2-96	96	4.0000	4.083

** LIGHTENING HOLES available upon request for gears 2 1/8 diameter and over.

71L (800) 243-0986
In CT (203) 775-4877

NORDEX